

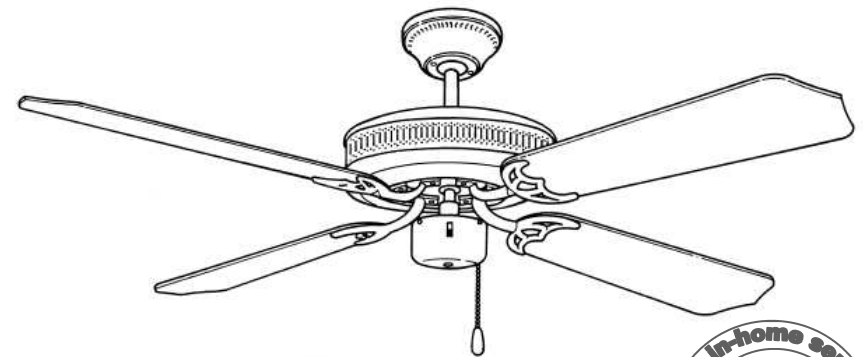

Owners Warranty & Operations Manual

Majestic Rosewood Ceiling Fan

Majestic Rosewood



**THIS MANUAL
MUST BE KEPT
BY FAN OWNERS**



*** In order to claim warranty, owners must be able to present product, installing electrician and purchase details as well as proof of purchase.***

[Please ensure your product, purchase and installing electrician's details are recorded on the back of this booklet, purchase receipts should be stapled onto the space provided inside this booklet]

The use of these products by children and the infirm must be under supervision.



Hunter Pacific International Pty Ltd
Head Office: Building 8, 256 New line Road,
New Line Business Park, Dural, NSW, Australia.
www.hunterpacific.com.au

National Warranty Line: 1300 360 280

Available Monday to Friday, from 9am to 5pm AEST.



Please Staple Purchase Receipts here



<u>PURCHASE DETAILS</u>			
Qty	Product Name	Purchase Place	Purchase Date
3	Concept ceiling fan	Hunter Pacific - Dural	12/10/2007

Follow the example given to fill out the product details.

Record your remote dip switch settings

Below are some spaces for you to record your remote dip switch settings in case you have more than one ceiling fan remote control. Use arrows to indicate the whether switches are pushed up or down on your remote hand piece.

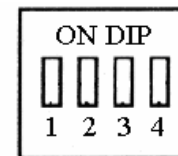

DIP SWITCH

Fan name: _____

Colour: _____

Location: _____ Date: _____

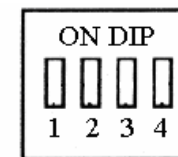

DIP SWITCH

Fan name: _____

Colour: _____

Location: _____ Date: _____



**Owners Warranty
&
Operations Manual**

Majestic Rosewood Ceiling Fan

CONTENTS PAGE

Fill out the details below and keep this booklet in a safe place. You will need to present your product, installing electrician, purchase details as well as proof of purchase to claim on site warranty.

CUSTOMER DETAILS

Customer Name: _____

Installation Site Address: _____

PRODUCT DETAILS

Qty	Code	Product Name	Install Area	Colour	Size
3	310	Concept ceiling fan	Lounge	White	132cm

Follow the example given to fill out the product details.
* You can find the code of your fan at the front of this booklet

INSTALLING ELECTRICIAN DETAILS

Electrical Company Name: _____

Electrician Name: _____

License No: _____

Telephone: _____

Mobile: _____

Signature: _____ Install Date: _____

- 1) **Parts List - Majestic Rosewood..... 2**
- 2) **Wall Controller Operations..... 3**
- 3) **Wall Controller FAQs.....3**
- 4) **Remote Control Operations..... 4**
- 5) **Remote FAQs..... 5**
- 6) **Pull Cord Operations..... 6**
- 7) **Summer/Winter Switch Operations..... 7**
- 8) **General Maintenance..... 8**
- 9) **Basic Trouble Shooting Tips..... 12**
- 10) **Warranty Information..... 14**
- 11) **Recording Product & Installing Electrician Details..... 16**
- 12) **Recording Purchase Details..... 17**
- 13) **Recording Remote Dipswitch Settings..... 4 & 17**

“Buy the Original Buy the Best!”



Owners Warranty & Operations Manual

Majestic Rosewood Ceiling Fan

Parts List - Majestic Rosewood

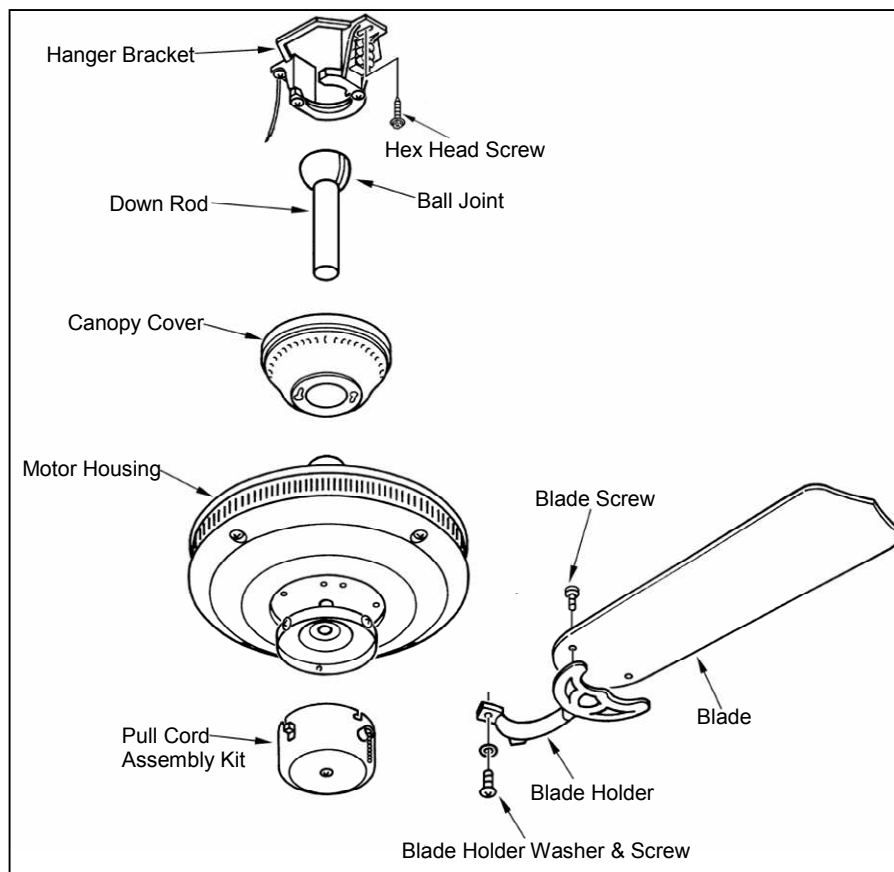

TICK	CODE	SIZE	FAN MODEL NAME	COLOUR
<input type="checkbox"/>	828	132cm, (52")	Majestic Rosewood	Rosewood

service call. Charges will be levied for Hunter Pacific International to arrange special access equipment and these must be paid in advance.

9) Blades must be replaced only as a complete set. Blades are supplied only as a pre-balanced set and the replacement of individual blades may void the warranty by causing mechanical damage to the motor, excessive noise or premature wear.

10) If goods are found to be free of defects or the product is not functioning properly as a result of faulty installation then Hunter Pacific International Pty Ltd reserves the right to charge the customer for the service fee.

11) Do not uninstall fan and do not return product to the retailer unless advise to. Instead call the warranty line on 1300 360 280 for further advise.

Warranty Periods:

1) *Ceiling fans*: 2 years in-home warranty and a further 3 years replacement parts warranty. This includes all parts of the motor housing and the blades as well as other small parts such as screws and canopy covers.

2) *Remote controls*: All Hunter Pacific remote controls have a 12 month warranty, including remotes sold in 'fan + remote' packages. Hunter Pacific remote controls includes both the remote receiver and the remote hand piece.

3) *Light kits*: 12 months warranty on all light kits, with the exception of light kits that are sold in 'fan + light' packages, these light kits are entitled to the same warranty as the fan.

What is in-home warranty?

Hunter Pacific offers 2 years in-home warranty to all Hunter Pacific ceiling fans installed within Australia. This warranty entitles users to have their ceiling fan serviced/repaired within their home free of charge in the case where the product fails to perform its intended function due to product fault, this warranty does not cover installation faults. In remote areas where a Hunter Pacific service agent is unable to reach the customer's home then Hunter Pacific will reimburse customers a standard fee for using their own service electrician. Conditions apply, service visits must be arranged with the Hunter Pacific warranty department. Please read warranty conditions and limitations.

What is replacement parts warranty?

On top of your 2 year in-home warranty, Hunter Pacific also offer users a further 3 years replacement parts warranty, that's a total of 5 years warranty! Hunter Pacific will happily replace defective parts of a HPI ceiling fan during its warranty period. Parts included in this list are as follows; motor, screws, canopy cover, standard down rods, wall controllers, speed capacitors, pull cords, blades and blade holders. Product parts will only be replaced if the parts are found to be faulty. Conditions apply, please read warranty conditions and limitations.

*The remotes and light kits 12 months warranty includes in-home repair service and replacement of faulty parts during the warranty period.



Owners Warranty & Operations Manual

Majestic Rosewood Ceiling Fan

7) Warranty

In the event that your Hunter Pacific ceiling fan has manufacturing defects or fails to perform its intended function in its warranty period, the Trade Practices Act of 1974 and similar laws in your state gives you the right under certain circumstances to have it made good. In addition, we will repair or replace a defective Hunter Pacific ceiling fan on the following terms and conditions.

Warranty conditions and limitations:

- 1) Warranty periods begin from the day of purchase. Product, installing electrician, purchase details and proof of purchase must be presented to service agents to claim on-site warranty.
- 2) Fans and fixed wiring products must only be installed by persons who are appropriately licensed by the applicable state regulatory body. Therefore, to protect our repair personnel, on-site warranty will not be accepted if products have been installed by unlicensed persons.
- 3) Damages caused by incorrect installation, force-majeure electrical surges, lightning, power grid fluctuations, water or by connection to alternative power supply sources (such as solar inverters etc), are not eligible for warranty repair.
- 4) Travelling costs incurred by Hunter Pacific personnel or a Hunter Pacific service agent beyond 25 km from authorised depots will not be covered by warranty. This cost must be covered by the customer.
- 5) This warranty will not be subjected to any statutory provisions to the contrary claims for damage to furniture, carpets, walls, ceilings, foundations or any other consequential loss either directly or indirectly resulting from a faulty ceiling fan.
- 6) This warranty will not cover any repairs to a Hunter Pacific product where the product was incorrectly used, physically abused, accidentally damaged or not serviced in accordance with the maintenance instructions.
- 7) Signals sent through the power by the supplier for the off peak hot water, street lights and other signals may cause a intermittent humming noise in the your electrical appliances such as your ceiling fan. Filters are available in Australia at the customer's expense. These noises do not occur as a result of a faulty fan.
- 8) When products are installed in a location requiring special access equipment (such as scaffolding or scissor lifts, etc) the cost of providing, installing and operating special access equipment must be borne by the site owner. The need for, or use of, such equipment must be stated when booking a

1) Wall Controller Operations

- 0** = fan is off
- I** = fan is on High speed
- II** = fan is on Medium speed
- III** = fan is on Low speed

E.g. In the picture to the right, the fan setting is set to zero thus the fan would be off.

WALL CONTROLLER FAQs

What speed should the fan be started on?

Fan should always be started on high speed. You should then slowly slow down your fan to the desired speed. Starting your fan on high speed is better for the motor and will help the motor last longer. High speed or speed one is matched to 240volts this gives your fan full voltage which also means your fan does not have to struggle to start.

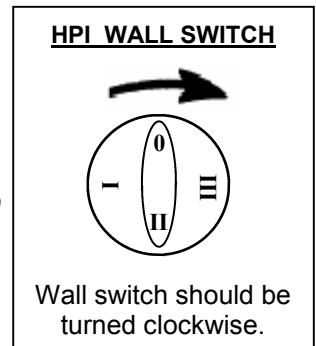

How many types of wall controllers does Hunter Pacific offer?

Hunter Pacific International only has one wall controller and this wall controller is used across our whole range of fans enabling you to have the same type of controller throughout your house for all of your ceiling fans. Hunter Pacific insists on having one standard wall controller to eliminate operating confusions.

Why are wall plates not included?

Hunter Pacific recognises the importance of waste minimization, from our years of operation our customers have always told us they prefer to use their existing wall plates or choose their own wall plates. Also often customers prefer to have more than one switch on their wall plates. Thus as a result of all this we have decided it was no longer necessary to include wall plates.

Why can't Hunter Pacific fans be installed on to variable or solid state controllers? Solid state and other variable wall controllers will cause a vibration/humming noise in the ceiling fan because they do not provide constant power supply to the fan.



Owners Warranty & Operations Manual

Majestic Rosewood Ceiling Fan

2) Remote Control Operations

All Hunter Pacific remote controls have three speed settings. Press and release to operate fan speeds. Press and release to operate light, if a dimming function is available then press and hold button to dim light.

Remote Speed Symbols

Off = Off	Stop = Off
H = High speed	Hi = High speed
M = Medium speed	Med = Medium speed
L = Low speed	Lo = Low speed

*Speed symbols will vary between different Hunter Pacific remote hand pieces. Above are two common types of symbols used on Hunter Pacific remote hand pieces.

LIGHT: The light button is only used to control the light on the ceiling fan. Some remotes will have an 'on' and 'off' button for light, where as some others may only have one light button which enables you to dim through the different light levels until you reach your desired level of lumens. Do not operate light globes totaling more than 150Watts on your remote control as this may damage the remote receiver.

Record your dip switch settings

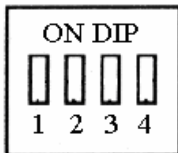

DIP SWITCH

- Use arrows to indicate whether switches are pushed up or down on your remote hand piece.
- It's a good idea to record your dip switch settings incase someone accidentally changes them.
- If you have more than one remote control, there are more spaces on the last page of this booklet.

Fan Model: _____ Location: _____

Understanding why your fan might wobble:

Slight wobble is normal, especially if the fan is on a extension rod. Ceiling fans tend to move during operation because they are not generally rigidly mounted. Rigidly mounting a ceiling fan could generate excessive ceiling vibration and stress on the mountings which can be very dangerous and thus should be avoided. Ceiling fans may move a couple of centimetres when in operation and does not suggest that the fan will fall down. Ceiling fans are mounted securely on steel brackets with ball joints to allow free movement. Not all ceiling fans are identical even if they are from the same model, some fans may spin faster and some may move more than others.

Fan is not moving much air:

- Check the reversing switch of the fan is in its correct position, the reverse switch should only be pushed into Winter position during the cold months of the year when you want to circulate warm air. The reversing switch should be put back into its Summer position during the warmer months of the year when cooling is required.
- The distance between the ceiling and the ceiling fan blades may be too small. Increasing this distance will help the fan perform more effectively, Hunter Pacific offers a range of down rods to solve this issue. Remember, legally there must be at least 2.1metres between your ceiling fan blades and the floor. Hunter Pacific recommends at least 2.4metres for metal fans.

You should also consider these factors:

- Does the room have too many items which may be obstructing efficient airflow?
- Is the fan too small for the size of the room?

Light is not working:

- Replace light globe, do not use low voltage or fluorescent lights.
- Switch off fan completely - make sure the light globe is secured properly into the light kit, if halogen globe feels loose, push metal prongs towards each other, this ensures the globe is secured and making proper contact with the metal prongs.
- If the fan is on a remote - Check for flat battery in the hand piece.
- If the fan is on a remote - Check dip switch settings on hand piece are matching the ones you wrote down in this booklet.

If in doubt call the HPI national warranty line - 1300 360 280



Owners Warranty & Operations Manual

Majestic Rosewood Ceiling Fan

6) Basic Trouble Shooting Tips

CAUTION: When performing any suggestions below in which you are required to touch the fan, make sure the fan is completely switched off.

Can not start fan:

- Check reversing switch is pushed into a position, either fully up or down, or fully left or right.
- If the fan is on a remote, check the isolation switch is turned on.
- If the fan is on a remote, check dip switch settings on remote hand piece are matching the dip switch settings you wrote down in this booklet.
- If pull cord fan, check the pull cord chain is set on high speed.

Fan sounds noisy:

- Fans that has just been installed may make a mechanical noise and should be given at least 8 hours settle-in period.
- If light kit is present, check light globes are secured firmly and ensure the glass of the light fitting and the fitting itself is not vibrating. Re-tighten all screws for the light kit.
- Re-tighten screws on all blades firmly, do not over tighten them.
- If the fan is on a wall controller. Make sure you are controlling your fan with the HPI wall controller supplied. Reinstallations of incorrect wall controllers are not covered by HPI warranty.

Fan is wobbling:

- If fan is wobbling a lot, check your ball joint is locked into position. Switch fan off completely, hold the down rod or motor housing then pull and rotate the rod or the motor housing until you can feel the ball joint slot back into place.
- Re-tighten all screws on blades firmly do not over tighten.
- Check and ensure all your blades are matching. All Hunter Pacific blades are marked with a set of letters and numbers. The letters on matching sets of blades will be identical, with the numbers varying within 3 grams of each other. At the factory blades are pre-balanced as a set thus, even if only one blade is damaged, you should still replace the whole set to avoid unbalanced blades.

Remotes FAQs

What speed should the fan be started on using a remote control? Your ceiling fan should always be started on high speed. You should then slowly slow down your fan to the desired speed. Starting your fan on high speed is better for the motor and will help the motor last longer. High speed or speed one is matched to 240volts this gives your fan full voltage which also means your fan does not have to struggle to start.

Is the fan speed affected if the fan is remote controlled rather than wall controlled? Yes, the fan speeds between a remote controlled fan and a wall controlled fan will be different even if they are the same model fans. This is because wall controlled fans have matching speed capacitors for each fan where as remote controls only have one standard set of speed capacitors for all fans.

Why can't I operate my fan from a wall controller as well as a remote control? It is not recommended that you operate your fan using a wall controller as well as a remote control because it may increase the risk of fire hazard.

What is an isolation switch and do I have to have one?

An isolation switch is a separate switch installed along with your remote control, note this is not a wall controller, this switch looks like a light switch and will only be used to supply power to your fan or to cut the power supply to your fan. If you are intending to install your fan onto a remote control then Hunter Pacific recommends that you have an isolation switch installed along with your remote control. It is important to have a separate isolation switch incase your remote control fails to function properly.

Can I use Hunter Pacific remote controls to operate other products? Hunter Pacific remote controls are only made for operating Hunter Pacific ceiling fans and Hunter Pacific light kits. Hunter Pacific remote controls are not suitable for low voltage lighting transformers. The use of a Hunter Pacific remote control on any item other than the specified will void your remote control warranty.

How often should I change the battery in my remote control?

Hunter Pacific recommends that you change the battery in your remote hand piece every 6 months to avoid battery leakages which may cause damage to your hand piece.



Owners Warranty & Operations Manual

Majestic Rosewood Ceiling Fan

3) Pull Cord Operations

Pull cord ceiling fans are fans that can be operated using a pull cord chain which hangs from the bottom of the fan. However there are other ways of operating a pull cord fan, please see below.

Pull chain position when fan is off:

Pull chain should be left on its 'off' position when the fan is off. To check this; turn remote/wall controller on to high speed then pull and release the pull chain until the fan turns off. Switch fan off again using wall/remote controller.

1) Pull cord fan with an isolation switch:

The fan must be turned on at the isolation switch for the fan to work. When turning the fan off always switch the fan off using the pull chain before turning the fan off at the isolation switch.

2) Pull cord fan with a remote control:

Pull chain should be left on high speed position during fan operation. You should then control your fan speeds using the remote control.

3) Pull cord fan with a wall controller:

Pull chain should be left on high speed position during fan operation. You should then control your fan speeds using the wall controller.

4) Pull cord fan with light:

The light should be operated on a separate wall switch if the fan is not on a remote control.

5) Pull cord fan wired directly with no other switch:

Use pull chain to control fan. When the fan is in its off position; 1st pull = High speed, 2nd pull = Medium speed, 3rd pull = Slow speed and 4th pull = off.

When cleaning a pull cord fan; always make sure you switch your fan off using the pull chain first then switch the fan off again using the remote control, wall controller or isolation switch.

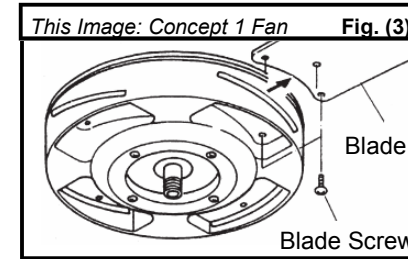

STEP 2 (Fig 3)

a) Now to remove the blades; loosen the blade screws and slide the blades out of the motor housing as shown in figure 3.

Cleaning Stainless Steel Fans: - People often think that if a product is made of stainless steel then it will be completely stain free. However, this is not the case, corrosion levels will vary depending on the conditions the product is put into, but you can help prevent tear stains and surface rusts through regular cleaning of your stainless steel products. Like all your other stainless steel products your stainless steel ceiling fan will also require regular cleaning.

To ensure your fan stays in good condition Hunter Pacific recommends at least seasonal cleaning of stainless steel fans especially ones that are installed in outdoor or coastal locations. Wipe the fan with a soft damp cloth to remove dust and excess moisture. After cleaning dry fan with a soft dry cloth then wipe the fan with a stainless steel product such as 'Cyndan Rapelle Stainless Steel Sentry' to maximise protection against rust corrosion. *See our website for further more information about stainless steel.

Cleaning Other Steel Fans: - Wipe the fan with a soft damp cloth to remove dust particles, non-abrasive cleaning products can be used to make the cleaning process easier. Do not use harsh products like bleach and always dry fan with a soft cloth after cleaning.

Normal Wear and Tear: - Threaded components working slightly loose or blade carriers even slightly bent due to vigorous cleaning or bumping can cause wobble and noise. This is not covered by warranty, but little care and maintenance can reduce or even prevent these problems.

finishes. **NOTE:** Hunter Pacific does not recommend wooden bladed fans to be used in outdoor installations, however if the fan must be installed in a outdoor location, ensure your fan is fully under shelter and be aware that your wooden blades will need to be cleaned more regularly and may need to be replaced more frequently.

Always use soft cloths to clean blades and motor housings to avoid scratching painted and plated finishes. Ideally your fan should be cleaned every 3 to 4 months.

STEPS TO REMOVING BLADES: (fan must be switched off)

NOTE: Remove and clean blades from each fan separately, do not mix blades from different fans as this can upset the balance of the fan.

Blades with blade holders:

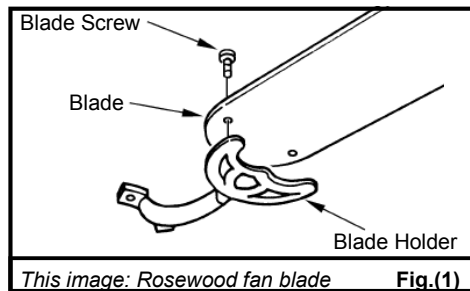

STEP 1 (Fig. 1)

a) Loosen blade screws to detach blade from blade holder. It is not necessary to remove blade holders.

Blades without blade holders:

STEP 1 (Fig 2)

a) To remove the base plate spread out your fingers and press your hand against the base plate of the motor housing and twist anticlockwise.
b) For fans with integrated light kits. Remove the glass and rim of the light kit to access the blades.

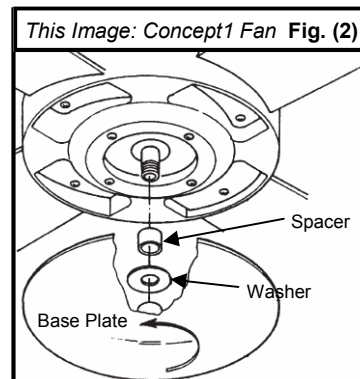

4) Summer/Winter Switch Operations

The location of the Summer and Winter switch will vary from fan to fan. On a standard Hunter Pacific ceiling fan you should be able to locate the summer/winter switch above the motor housing (figure 1). On the Hunter Pacific pull cord fans you will find the switch located outside the pull cord assembly kit (figure 2).

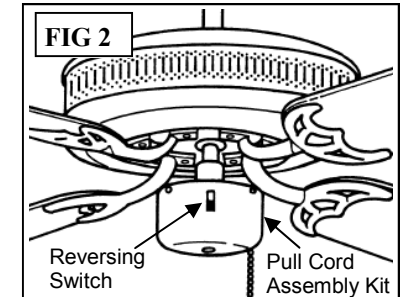
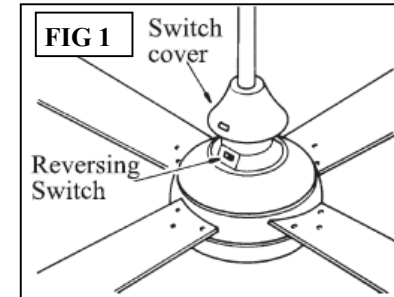

NOTE: The summer/winter switch must always be locked into a position for the fan to operate. Always check the switch is locked into its correct position after cleaning.

Understanding the reversing switch

Ceiling fans are an environmentally smart choice for cooling and warming your home.

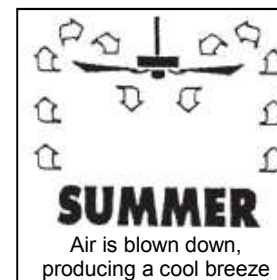

In Summer mode your fan should be put into Summer mode. Your ceiling fan will spin anticlockwise to push cool air down the centre of the fan producing a cooling breeze.

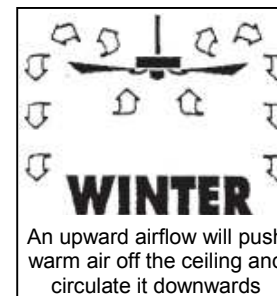

In Winter mode your ceiling fan will spin clockwise. Air is drawn up the centre of the fan, which pushes the warm air off the ceiling and circulates it down to the living areas. Your fan should be operated on slower speeds in Winter than Summer. The Winter mode can also be for light air circulation in air-tight rooms.

CAUTION: Always ensure the fan is off and the blades have stopped spinning before attempting to reverse the fan.

5) General Maintenance

Switch off the fan completely before performing any maintenance.

Changing Light Globes - It is important to turn off all power to the fan before you change globes on your fan light. Remember to use a tissue to hold the globe if you are replacing a halogen globe. Avoid touching the halogen globe with your fingers as body moisture and dirt may shorten the life span of the globe. Do not exceed suggested light globe wattages.

CAUTION: HOT! Always allow the globe to cool down before you attempt to change the globe.

NOTE: Our current light kits do not support fluorescent lamps and low voltage globes.

STEPS TO CHANGING HALOGEN GLOBES:

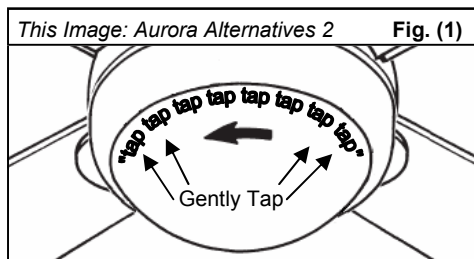

Step 1) Fig. (1)

- a) Loosen the glass base of the light kit by gently tapping around the edge of it.
- b) To remove glass, twist the glass base of the light anticlockwise.

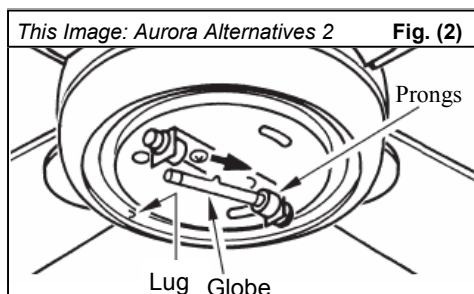

Step 2) Fig. (2)

- a) Use a tissue to hold the halogen globe. Push the globe to one side of the spring loaded prongs and remove the globe. As shown in the image on the left.

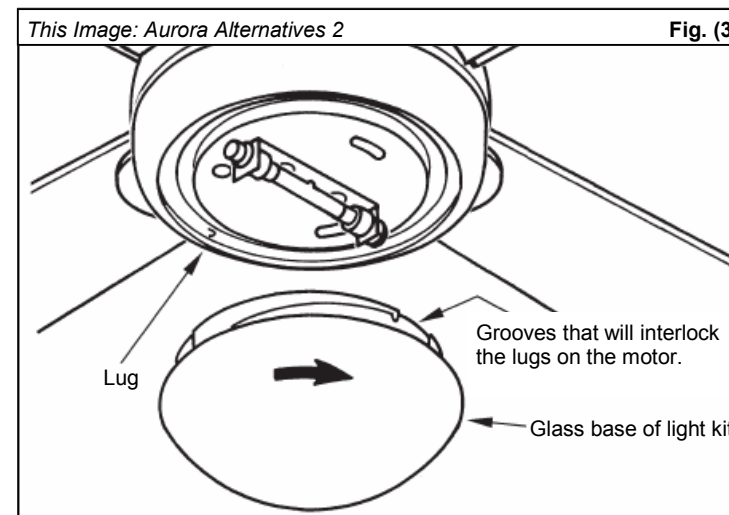

Step 3) Fig. (3)

- a) Refit a new globe. This time with a tissue hold the new globe and insert it into the metal prongs. Ensure the globe is secured firmly, if the globes appears to be loose, push the ends of the metal prongs towards each other until the globe is secured.
- b) Now put the glass base back on, tighten the glass by slowly and gently turning it clockwise, do not over tighten the glass as you may find it very hard to remove next time.

Changing Remote Batteries: - Batteries used in remote hand pieces will weaken over time and should be replaced every 6 months before leakage occurs as this will damage the hand piece. Batteries removed from the remote hand piece should be disposed properly and kept out of reach of children.

Always ensure fan is completely switched off and cooled down before you start cleaning

Cleaning the Motor Housings: - Motor housings should be regularly cleaned to avoid build up of dust which may fall into the internal workings of the motor housing. Use a soft dry cloth to remove dust.

Cleaning the Blades: - Use a soft damp cloth to remove dust particles from blades. Always dry blades with a soft dry cloth after cleaning. Blades should not be left damp or wet as this will damage blade