

PLEASE RETAIN FOR WARRANTY

Please Note: Warranty form must be completed with all details and stapled together with the purchase receipt and retained.

WARNING: Fan must be installed by a licensed electrician according to S.A.A and local authority regulations.

1. Fan and Light are to be earthed, bracket must be firmly screwed to a solid structure eg concrete ceiling, steel structure or timber frame. If timber frame is to be added it must be nailed between two beams. If this is not possible contact our service line for further instruction.
 2. Do not attempt to control the operation of this fan (or optional light kit) from any wall control that is not approved by Hunter Pacific International for use with its fan. The wall controller may be replaced with a capacitor style wall controller of another brand, to ensure correct speed use the same value capacitors as supplied with the product. **DO NOT** use solid state wall controllers. The ceiling fans may be installed on a home automation system provided capacitors are used to control the speed, only suitable if used with specified control relay units. Contact our service line for further information.
 3. Close supervision is necessary when the product is used by children or invalid people, do not allow children to use as a toy.
 4. Caution – blades must be at least 210cm (7 feet) from the floor in accordance with the Australian safety standards
- **The use of a wall controller that is not approved by HUNTER PACIFIC INTERNATIONAL PTY LTD voids the warranty**
 - **DO NOT REMOVE THE FAN FROM THE CEILING AFTER INSTALLATION**
 - **IF THERE ARE ANY PROBLEMS AT INSTALLTION THE ELECTRICIAN SHOULD CONTACT THE WARRANTY LINE BEFORE LEAVING THE JOB**

**PLEASE DO NOT PHONE THE RETAILER FOR WARRANTY
PLEASE PHONE**

1300 360 280

FOR ALL WARRANTY ENQUIRIES

Warning: Do not attempt to control the operation of the fan (or optional light kit) from any wall control that is not approved by Hunter Pacific International for use with the fans. Do not use solid state wall controllers. The use of an unapproved wall control voids the warranty.

Warning : Do not mix blade sets from one fan to another. If only one blade is damaged you are still required to replace with a complete new set.

Parts List

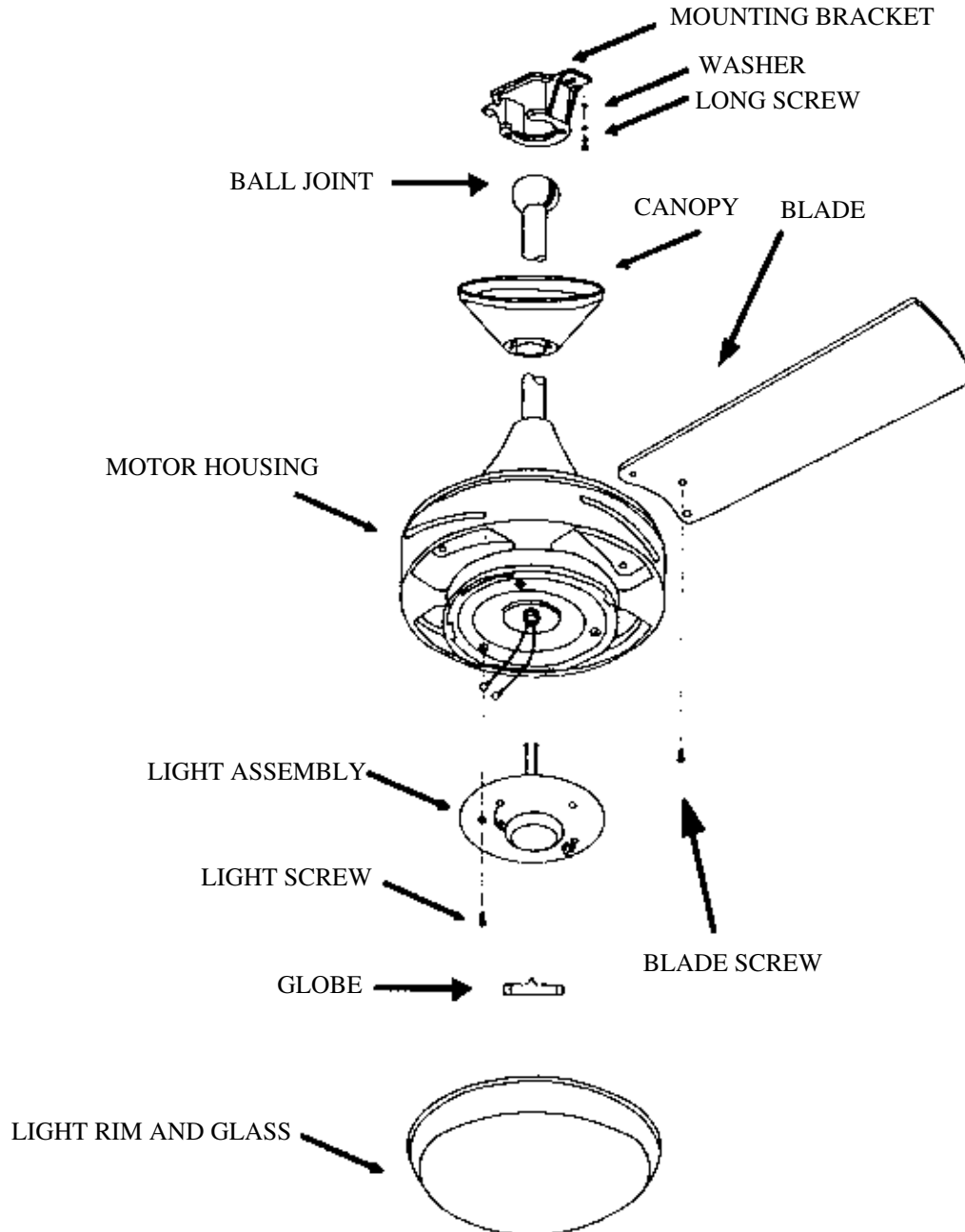

Warning: Do not attempt to control the operation of the fan (or optional light kit) from any wall control that is not approved by Hunter Pacific International for use with the fans. Do not use solid state wall controllers. The use of an unapproved wall control voids the warranty.

Warning : Do not mix blade sets from one fan to another. If only one blade is damaged you are still required to replace with a complete new set.

Installation Instructions

Assembly Instructions

1. Secure the mounting bracket to the ceiling joist or suitable piece of timber inserted between the ceiling joist; the bracket should be attached with the two (2) long screws provided.

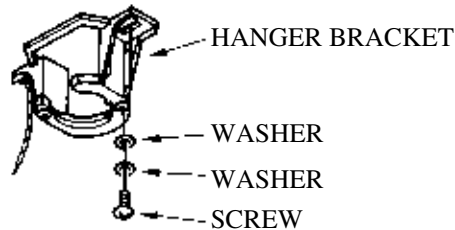

(Fig 1)

2. Insert the ball joint of the fan unit into the mounting bracket, lining up ball joint slot with hanger bracket as shown (fig2). Do not sit the ball joint in the bracket and rotate as the paint may be scratched, ensure that the securing structure is aligned before lowering the ball joint into the mount.

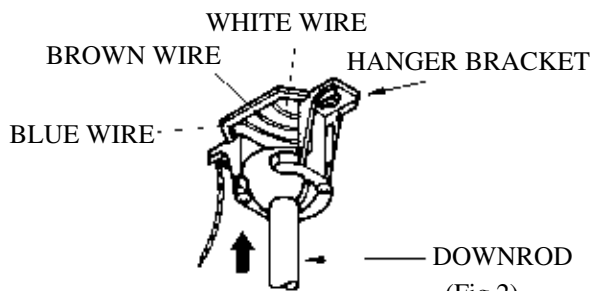

(Fig 2)

3. After wiring attach the canopy to the hanger bracket by pushing up (fig3) and twisting to locate screws in Key holes then tighten screws

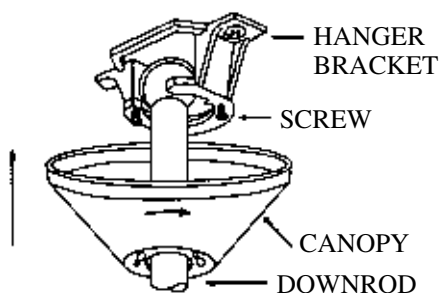

(Fig 3)

4. Attach the screw cover by gently moving upwards towards the canopy and twisting clockwise to secure the cover onto the screw heads

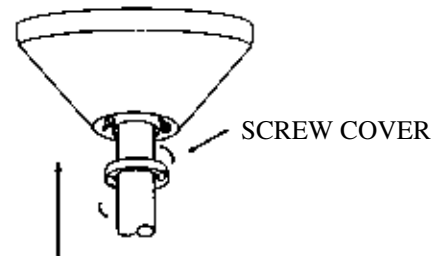

(Fig 4)

Installing Blades

Attach the blade to the blade holder with the three (3) screws and washers provided. Tighten them securely. Repeat this procedure for all four (4) blades

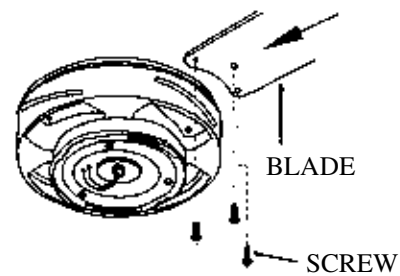

(Fig 5)

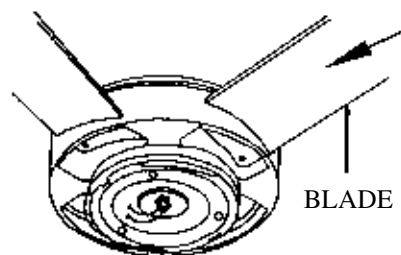

(Fig 6)

Warning: Do not attempt to control the operation of the fan (or optional light kit) from any wall control that is not approved by Hunter Pacific International for use with the fans. Do not use solid state wall controllers. The use of an unapproved wall control voids the warranty.

Warning : Do not mix blade sets from one fan to another. If only one blade is damaged you are still required to replace with a complete new set.

Wiring Instructions (with and without accessory light)

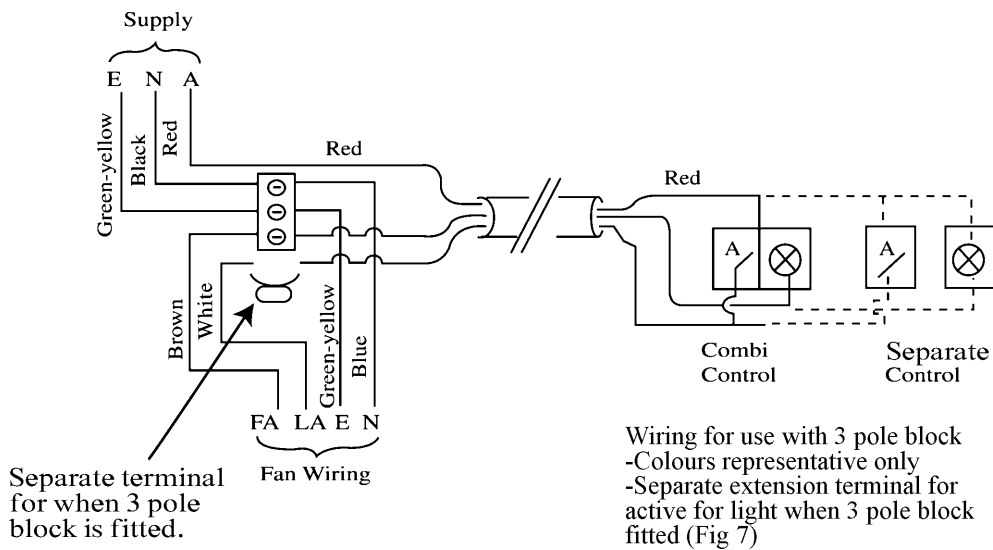

Extension Rod (26mm diameter)

91cm/1.8m (if required) Hunter Pacific International Extension Rods only to be used

To remove standard down rod from fan untighten earth screw and remove down rod yolk pin (Fig 8).

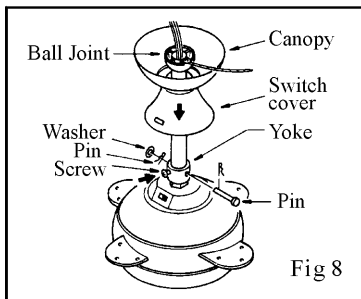

Back off ball joint earth screw and remove the ball joint pin, ball joint and cover (Fig 9)

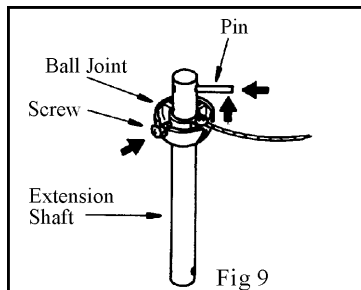

If extension rod is to be shortened, cut to required length and drill appropriate hole size to fit ball joint pin. The cut end of the extension should be deburred. The cut end should be used on the ball joint end only. Install extension rod by reversing the removal process (Fig 10/Fig 11)

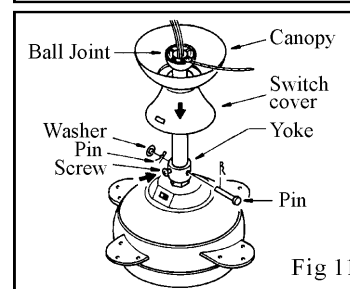
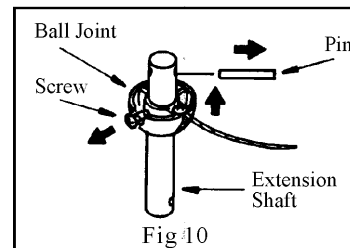

Please note when installing a 1.8m extension rod the wiring will need to be extended and joined. This should be done using crimp style connectors. All materials including extra loom and connectors should be supplied by the installing electrician. To ensure safety and a easy fit into the down rod stagger the connectors at different lengths on the wiring.

Warning: Do not attempt to control the operation of the fan (or optional light kit) from any wall control that is not approved by Hunter Pacific International for use with the fans. Do not use solid state wall controllers. The use of an unapproved wall control voids the warranty.

Warning : Do not mix blade sets from one fan to another. If only one blade is damaged you are still required to replace with a complete new set.

Fitting Cover Without Light

Align base plate cover with the securing assembly, turn gently clockwise until secured tightly.

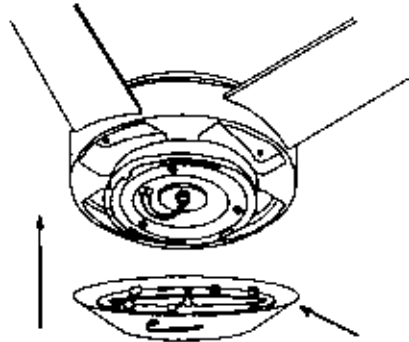

BASE PLATE

(Fig 12)

Removing Cover

Screw cover anticlockwise, gently removing from base plate mounting assembly on the final turn.

Reversing Switch

Switch should be in down position for Summer (anticlockwise) and up for winter (clockwise).

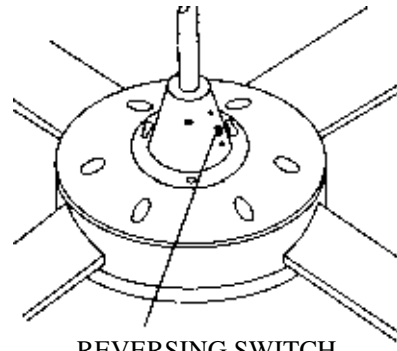

REVERSING SWITCH

(Fig 13)

Warning: Do not attempt to control the operation of the fan (or optional light kit) from any wall control that is not approved by Hunter Pacific International for use with the fans. Do not use solid state wall controllers. The use of an unapproved wall control voids the warranty.

Warning : Do not mix blade sets from one fan to another. If only one blade is damaged you are still required to replace with a complete new set.

Fitting Cover with Light

Remove base plate by applying upward and anticlockwise pressure (Fig 14)

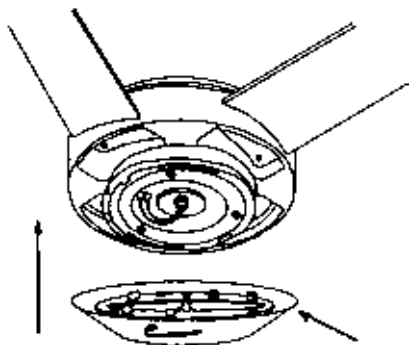

(Fig 14)

BASE PLATE

Attach the Light assembly using the connectors provided. Secure the plate using 3 screws. (Fig 15)

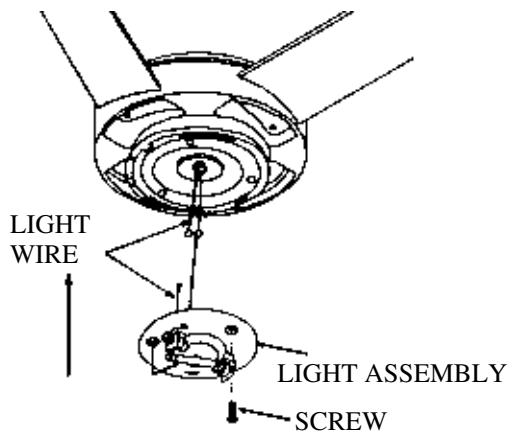

(Fig 15)

Install the glass by gently pushing the light rim and glass upwards and spinning clockwise into the light support bracket. (Fig 16)

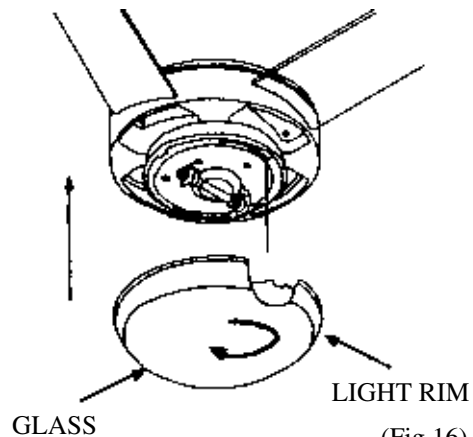

(Fig 16)

Installing Light Globe

Bulb max 100w Quartz Halogen.

Plug the halogen bulb into the socket. Do not touch the glass bulb with your fingers. It is extremely important that the glass be clean. If it is touched, or dirty, clean carefully with a tissue. A dirty glass bulb will cause the bulb to fail almost immediately.

Warning: Do not attempt to control the operation of the fan (or optional light kit) from any wall control that is not approved by Hunter Pacific International for use with the fans. Do not use solid state wall controllers. The use of an unapproved wall control voids the warranty.

Warning : Do not mix blade sets from one fan to another. If only one blade is damaged you are still required to replace with a complete new set.

To Licensed Installers and Fan owners
Please Read Before Calling for Warranty

FAN WILL NOT START

- check main circuit breakers
- check wire connections to the fan
- check speed controller position
- push reversing switch fully up or down

FAN SOUNDS NOISY

- Check suggested bulb(s) in light kit
- Re-tighten all screws on fan blades but never over tighten
- Retighten all screws in the hanging bracket or plat
- Change the controller to the one supplied.

MECHANICAL NOISE

- allow for at least 8 hours settling in time

FAN MOVES BUT DOES NOT MOVE MUCH AIR

- the fan may be running in reverse
- the distance between the ceiling and the fan blades maybe too small
- The room may contain items which obstruct the air flow.
- The fan may be too small for the size of the room.

POINTS AT A GLANCE

- All electric motors, including fan motors make some noise and may feel hot to touch this is NOT a fault.
- Ceiling fans tend to move during operation due to the fact that they are not generally rigidly mounted - if they were they could generate excessive ceiling vibration and stress on the mountings. Movement of a couple of centimeters is quite normal and does not suggest that the fan will fall down. Ceiling fans are mounted securely on steel brackets with rubber cushioning or with ball joints to allow free movement. Please Note - all ceiling fans are not the same even in the same model - some may move more than others .

Fan lights can rattle, if they are not supplied with the fan in the box they are not covered by warranty.

REVERSING SWITCH

Switch should be in the down position for summer (anticlockwise) and in the up position for winter (clockwise)(Fig 17)

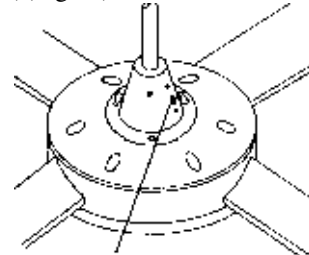

REVERSING SWITCH (Fig 17)

FAN OPERATION

A ceiling fan is an environmentally smart choice to cool as well as help warm your room. You should see a reduction in both cooling and heating costs by regular use of your fans. Do not hesitate to use your fans in both the summer and winter months. In summer place the reverse switch in the forward position (fan should spin in an anti clockwise direction) so cool air is blowing down producing a cool breeze.

In winter, reverse the switch (fan should spin in a clock wise direction) so that an upward airflow will push warm air off the ceiling and circulate it downwards into the living areas. In the winter months use the fan at a lower speed than in summer.

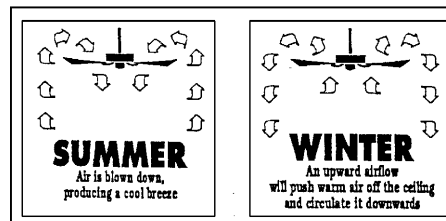

NORMAL WEAR AND TEAR

Threaded components working slightly loose or blade carriers even slightly bent during to vigorous cleaning or bumping can cause extra wobble and noise. This is not covered under warranty but a little care and maintenance can reduce or prevent this problem.

Warning: Do not attempt to control the operation of the fan (or optional light kit) from any wall control that is not approved by Hunter Pacific International for use with the fans. Do not use solid state wall controllers. The use of an unapproved wall control voids the warranty.

Warning : Do not mix blade sets from one fan to another. If only one blade is damaged you are still required to replace with a complete new set.

Ceiling Fan Warranty

In the event that your hunter pacific ceiling fan has manufacturing defects or fails to perform its intended function in the warranty period, the Trade Practices Act of 1974 and similar laws in your state give you the right under certain circumstances to have it made good. In addition, we repair or replace defective Hunter Pacific ceiling fans on the following terms and conditions.

Ceiling Fan Warranty Period

The appliance is covered by a 2 year in house warranty and a further 3 year replacement on the motor only.

Warranty on Replacement Fans

Ceiling fans replaced under warranty are warranted only for the balance of their warranty period.

Conditions and Exclusions

- Repair or replacement work will be carried out free of charge by Hunter Pacific International or its approved agent or on the basis shown above, subject to dated proof of purchase.
- The following is not covered.
- Travelling costs incurred by Hunter Pacific personnel or service agent beyond 25km from Hunter Pacific authorised service depots and /or the cost of transporting and insuring the ceiling fan between the nearest Hunter Pacific agents service depot and its normal location. The costs must be met by the purchaser.
- The cost of the work or service call where there is nothing wrong with the ceiling fan or where the defective operation of the ceiling fan is due to failure of electricity, not in accordance with Hunter Pacific instructions and/or applicable local regulations and where defects caused by incorrect application or abuse of the ceiling fan, or damage caused by unauthorised persons attempting to repair the ceiling fan.
- Subject to any statutory provisions to the contrary claims for damage to furniture, carpet, wall ceilings, foundations or any other consequential loss either directly or indirectly resulting from a faulty ceiling fan.
- Repair a ceiling fan incorrectly used accidentally damaged or not serviced in accordance with the maintenance instructions.
- Ceiling fans not installed by a licensed electrician.
- The remote controls (Hunter Pacific International Pty Ltd model only) are an accessory product covered by a one year warranty.
- All signals sent through the power by the supplier for the off peak off hot water and other signals including street light and such. These signals may cause an intermittent humming noise in the ceiling fan. Filters are available in Australia at customer cost. It is not the fault of the ceiling fan.
- Warranty does not transfer from original purchaser.
- The Hunter Pacific International fan is not purchased and installed in Australia
- Accessory light

**Warranty Hotline number Australia only 9am to 5 pm EST
1300 360 280**

Please Note When phoning for warranty you will require the date of purchase, retailer, model, colour and size of the fan (Electricians details may also be required).

Warning: Do not attempt to control the operation of the fan (or optional light kit) from any wall control that is not approved by Hunter Pacific International for use with the fans. Do not use solid state wall controllers. The use of an unapproved wall control voids the warranty.

Warning : Do not mix blade sets from one fan to another. If only one blade is damaged you are still required to replace with a complete new set.

Ceiling Fan Warranty Details

Please File with you Purchase receipt

Customer Details

Name _____

Address _____

Post Code _____

Phone Number _____

Fan Details

Model _____

Colour _____

Size _____

Date of Purchase _____

Purchased From _____

Electricians Details

Name of Electrician _____

License Number _____

Phone Number _____

Warning: Do not attempt to control the operation of the fan (or optional light kit) from any wall control that is not approved by Hunter Pacific International for use with the fans. Do not use solid state wall controllers. The use of an unapproved wall control voids the warranty.

Warning : Do not mix blade sets from one fan to another. If only one blade is damaged you are still required to replace with a complete new set.

