

PLEASE RETAIN FOR WARRANTY

Please Note: Warranty form must be filled with all details completed and stapled together with the purchase receipt and retained.

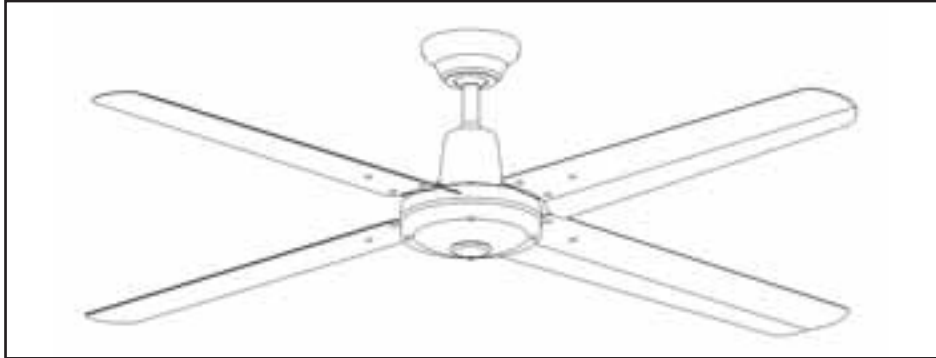

Warning fan must be installed by a licensed electrician according to S.A.A and local authority regulations.

1. Fan and Light are to be earthed, bracket must be firmly screwed to a solid structure eg concrete ceiling, steel structure or timber frame. If timber frame is to be added it must be nailed between two beams
2. Do not attempt to control the operation of this fan (or optional light kit) from any wall control that is not approved by Hunter Pacific International for use with its fan. DO NOT use solid state wall controllers.
3. Close supervision is necessary when the product is used by children or invalid people, do not allow children to use as a toy.
4. Caution - blades must be at least 7 feet (210cm) from the floor

➤ **DO NOT REMOVE THE FAN FROM THE CEILING AFTER INSTALLATION**

➤ **IF THERE ARE ANY PROBLEMS AT INSTALLATION THE ELECTRICIAN SHOULD CONTACT THE WARRANTY LINE BEFORE LEAVING THE JOB**

**PLEASE DO NOT PHONE THE RETAILER FOR
WARRANTY
PLEASE PHONE
1300 360 280
FOR ALL WARRANTY ENQUIRIES**

Warning: Do not attempt to control the operation of the fan (or optional light kit) from any wall control that is not approved by Hunter Pacific International for use with the fans. Do not use solid state wall controllers. The use of an unapproved wall control voids the warranty.

Warning : Do not mix blade sets from one fan to another. If only one blade is damaged you are still required to replace with a complete new set.

Parts List

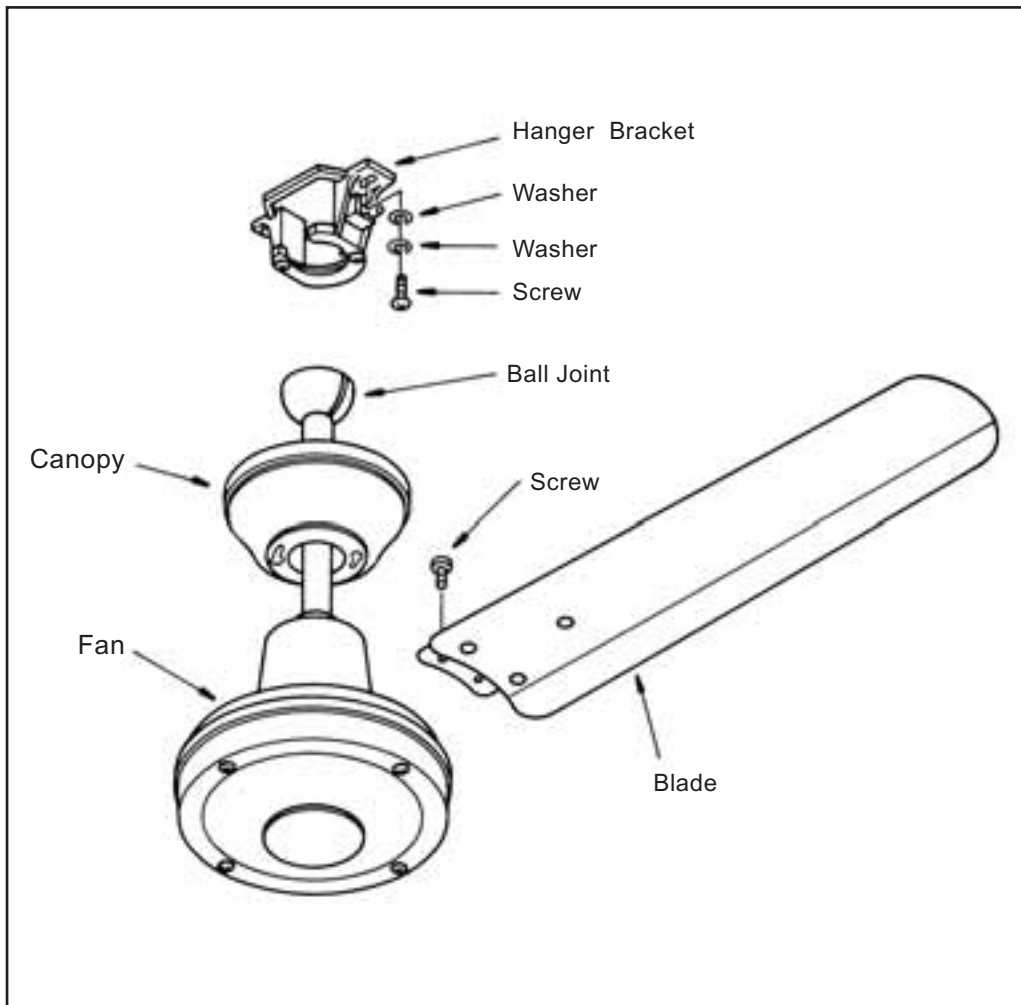

Warning: Do not attempt to control the operation of the fan (or optional light kit) from any wall control that is not approved by Hunter Pacific International for use with the fans. Do not use solid state wall controllers. The use of an unapproved wall control voids the warranty.

Warning : Do not mix blade sets from one fan to another. If only one blade is damaged you are still required to replace with a complete new set

Installation Instructions

Assembly Instructions

Secure the hanger bracket to the ceiling joist or suitable piece of timber inserted between the ceiling joist; the bracket should be attached with (2) long screws supplied

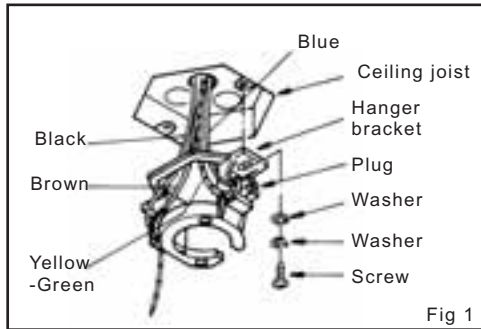

Place the fan unit into the hanger bracket, lining up ball joint slot with hanger bracket as shown

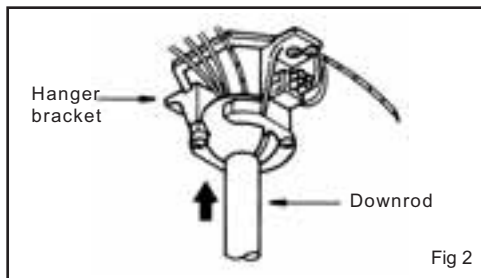

After wiring attach the canopy to the hanger bracket by pushing up and twisting to locate screws in Key holes then tighten screws

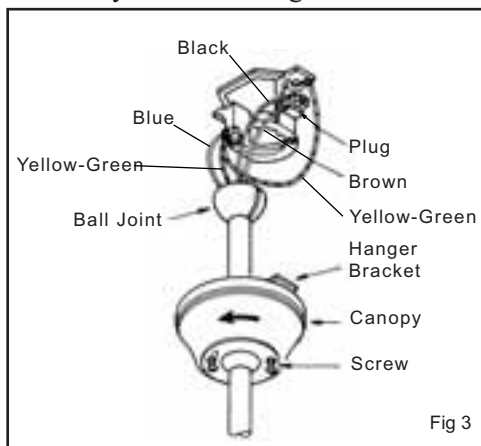

Installing Blades

Attach the blade to the top of the motor with two (2) blade screws and washers provided. Tighten them securely. Repeat this procedure for all blades (fig 4)

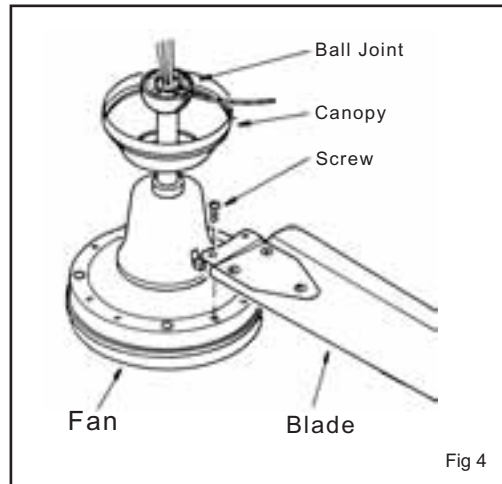

Warning: Do not attempt to control the operation of the fan (or optional light kit) from any wall control that is not approved by Hunter Pacific International for use with the fans. Do not use solid state wall controllers. The use of an unapproved wall control voids the warranty.

Warning : Do not mix blade sets from one fan to another. If only one blade is damaged you are still required to replace with a complete new set.

Wiring Instructions (with and without accessory light)

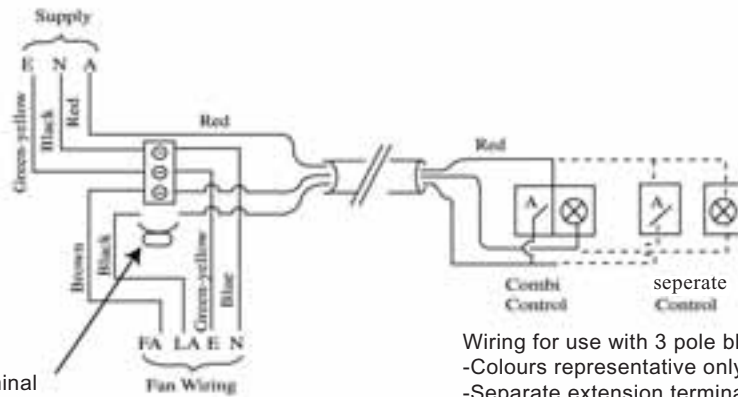

Seperate terminal for when 3 pole block is fitted.

Wiring for use with 3 pole block
-Colours representative only
-Separate extension terminal for active for light when 3 pole block fitted

Extension Rod

91cm/1.8m (if required) Hunter Pacific International Extension Rods only to be used)

To remove standard down rod from fan untighten earth screw and remove down rod yolk pin (fig 5). **Aurora Fan Shown**

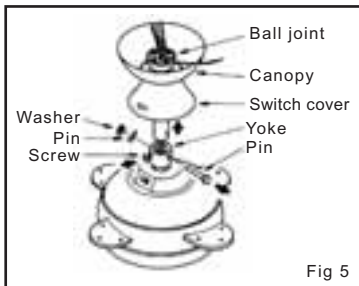

Fig 5

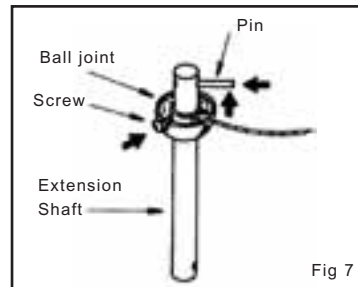

Fig 7

Back off ball joint earth screw and remove the ball joint pin, ball joint and cover (fig 6)

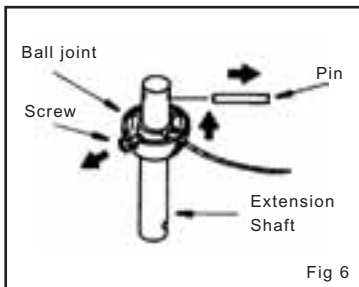

Fig 6

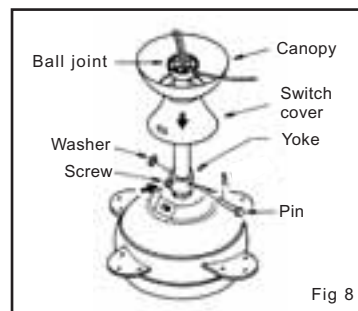

Fig 8

Please note when installing a 1.8m extension rod the wiring will need to be extended and joined. This should be done using crimp style connectors.

Warning: Do not attempt to control the operation of the fan (or optional light kit) from any wall control that is not approved by Hunter Pacific International for use with the fans. Do not use solid state wall controllers. The use of an unapproved wall control voids the warranty.

Warning : Do not mix blade sets from one fan to another. If only one blade is damaged you are still required to replace with a complete new set.

Installation of accessory Light Kit

Light wires are inside motor shaft and should be retrieved by using a pair of long nosed pliers. The light fitting must have a 10mm thread. The light fitting is simply screwed (fig 10) into the bottom housing of the motor shaft. Connection of wires must be made inside accessory light fitting insuring wiring and connections is insulated where applicable. using crimp connector one fan wire and one light wire should be crimped together, this process should be repeated.

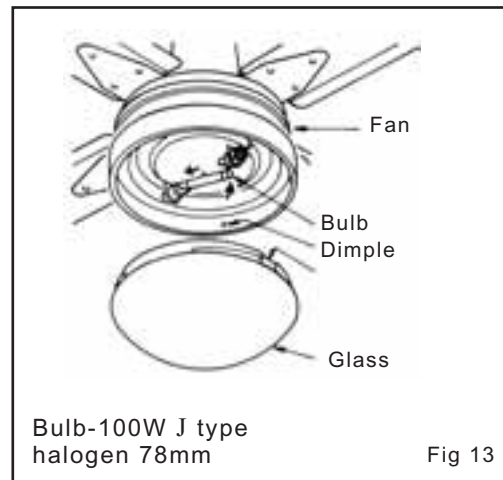
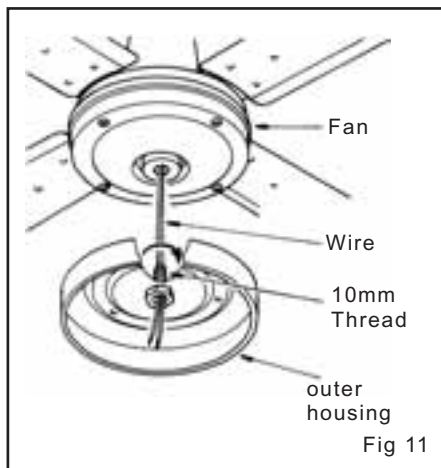
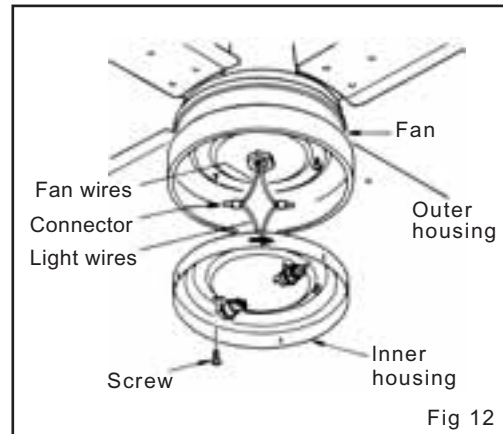
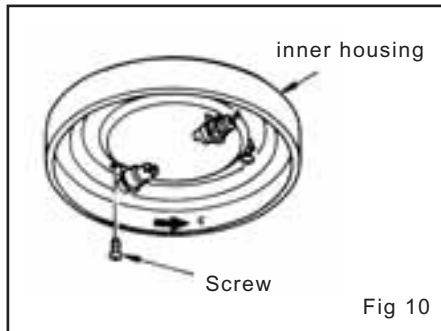

Warning: Do not attempt to control the operation of the fan (or optional light kit) from any wall control that is not approved by Hunter Pacific International for use with the fans. Do not use solid state wall controllers. The use of an unapproved wall control voids the warranty.

Warning : Do not mix blade sets from one fan to another. If only one blade is damaged you are still required to replace with a complete new set

To Licensed Installers and Fan owners Please Read Before Calling for Warranty

FAN WILL NOT START

- check main circuit breakers
- check wire connections to the fan
- check speed controller position
- push reversing switch fully up or down

FAN SOUNDS NOISY

- Check suggested bulb(s) in light kit
- Re-tighten all screws on fan blades but never over tighten
- Retighten all screws in the hanging bracket or plate
- Change the controller to the one supplied.

MECHANICAL NOISE

- allow for at least 8 hours settling in time

FAN MOVES BUT DOES NOT MOVE MUCH AIR

- the fan may be running in reverse
- the distance between the ceiling and the fan blades maybe too small
- The room may contain item which obstruct the air flow.
- The fan may be too small for the size of the room.

POINTS AT A GLANCE

All electronic motors, including fan motors make some noise and may feel hot to touch this is NOT a fault.
Ceiling fans tend to move during operation due to the fact that they are not generally rigidly mounted - if they were they could generate excessive ceiling vibration and stress on the mountings. Movement of a couple of centimetres is quite ok and does not suggest that the fan will fall down. Ceiling fans are mounted securely on steel brackets with rubber cushioning or with ball joints to allow free movement. Please Note - all ceiling fans are not the same even in the same model - some may move more than others .? Fan lights can rattle, if they are not supplied with the fan in the box they are not covered by warranty.

REVERSING SWITCH

Switch should be in the down position for summer (anticlockwise) and in the up position for winter (clockwise)(fig 11)

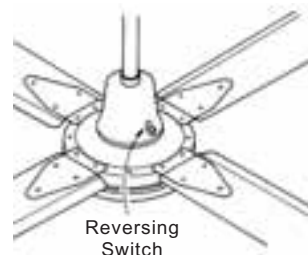

FAN OPERATION

A ceiling fan is an environmentally smart choice to cool as well as help warm your room. You should see a reduction in both cooling and heating costs by regular use of your fans. Do not hesitate to use your fans in both the summer and winter months. In summer place the reverse switch in the up position (fan should spin in an anti clockwise direction) so cool air is blowing down producing a cool breeze. In winter, reverse the switch (fan should spin in a clock wise direction) so that an upward airflow will push warm air off the ceiling and circulate it downwards into the living areas. In the winter months use the fan at a lower speed than in summer.



NORMAL WEAR AND TEAR

Threaded components working slightly loose or blade carriers even slightly bent during vigorous cleaning or bumping can cause extra wobble and noise. This is not covered under warranty but a little care and maintenance can reduce or prevent this problem.

Warning: Do not attempt to control the operation of the fan (or optional light kit) from any wall control that is not approved by Hunter Pacific International for use with the fans. Do not use solid state wall controllers. The use of an unapproved wall control voids the warranty.

Warning : Do not mix blade sets from one fan to another. If only one blade is damaged you are still required to replace with a complete new set.

Ceiling Fan Warranty

In the event that your Hunter Pacific ceiling fan has manufacturing defects or fails to perform its intended function in the warranty period, the Trade Practices Act of 1974 and similar laws in your state give you the right under certain circumstances to have it made good. In addition, we repair or replace defective Hunter Pacific ceiling fans on the following terms and conditions.

Ceiling Fan Warranty Period

The appliance is covered by a 2 year in house warranty and a 5 year replacement on the motor only.

Warranty on Replacement Fans

Ceiling fans replaced under warranty are warranted only for the balance of their warranty period.

Conditions and Exclusions

Repair or replacement work will be carried out free of charge by Hunter Pacific International or its approved agent or on the basis shown above, subject to dated proof of purchase.

The following is NOT covered

Travelling costs incurred by Hunter Pacific personnel or service agent beyond 25km from Hunter Pacific authorised service depots and /or the cost of transporting and insuring the ceiling fan between the nearest Hunter Pacific agents service depot and its normal location. The costs must be met by the purchaser.

The cost of the work or service call where there is nothing wrong with the ceiling fan or where the defective operation of the ceiling fan is due to failure of electricity, not in accordance with Hunter Pacific instructions and/or applicable local regulations and where defects caused by incorrect application or abuse of the ceiling fan, or damage caused by unauthorised persons attempting to repair the ceiling fan.

Subject to any statutory provisions to the contrary claims for damage to furniture, carpet, wall ceilings, foundations or any other consequential loss either directly or indirectly resulting from a faulty ceiling fan.

Repair a ceiling fan incorrectly used accidentally damaged or not serviced in accordance with the maintenance instructions.

Ceiling fans not installed by a licensed electrician.

The remote controls (Hunter Pacific International Pty Ltd model only) are an accessory product covered by a one year warranty.

All signals sent through the power by the supplier for the off peak hot water and other signals including street light and such. These signals may cause an intermittent humming noise in the ceiling fan. Filters are available in Australia at customer cost. It is not the fault of the ceiling fan.

Warranty does not transfer from original purchaser.

The Hunter Pacific International fan is not purchased and installed in Australia

Accessory light

Warranty Hotline number Australia only 9am to 5 pm EST 1300 360 280

Please Note When phoning for warranty you will require the date of purchase, retailer, model, colour and size of the fan (Electricians details may also be required).

Warning: Do not attempt to control the operation of the fan (or optional light kit) from any wall control that is not approved by Hunter Pacific International for use with the fans. Do not use solid state wall controllers. The use of an unapproved wall control voids the warranty.

Warning : Do not mix blade sets from one fan to another. If only one blade is damaged you are still required to replace with a complete new set.

Ceiling Fan Warranty Details

Please File with you Purchase receipt

Customer Details

Name _____

Address _____

Post Code _____

Phone Number _____

Fan Details

Model _____

Colour _____

Size _____

Date of Purchase _____

Purchased From _____

Electricians Details

Name of Electrician _____

License Number _____

Phone Number _____

Warning: Do not attempt to control the operation of the fan (or optional light kit) from any wall control that is not approved by Hunter Pacific International for use with the fans. Do not use solid state wall controllers. The use of an unapproved wall control voids the warranty.

Warning : Do not mix blade sets from one fan to another. If only one blade is damaged you are still required to replace with a complete new set.